

**Watt Plastics Ltd**

*Broken Brea farm - Easby - Richmond - North Yorkshire - DL10 7EY*

*Tel: 01748 822666 . Fax: 08706221997*

*Web: [www.wattfences.com](http://www.wattfences.com) | Email: [bill@wattfences.com](mailto:bill@wattfences.com)*

# PVC Post & Rail Fence

## PART LIST

### RANCH RAIL INCLUDES:

- A. 5"x5" Post
- B. 5" Standard Caps
- C. 1-1/2" x 5-1/2" or 2"x6" Rails

Standard Cap

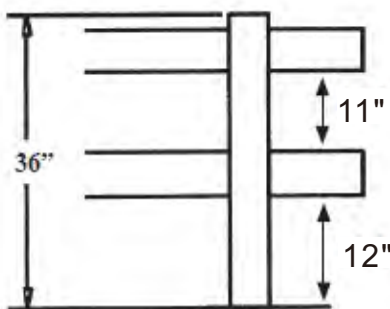
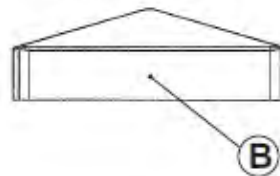

2 RAIL DIMENSIONS

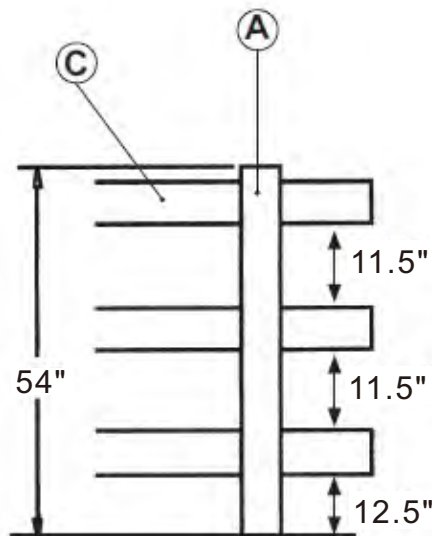

3 RAIL DIMENSIONS

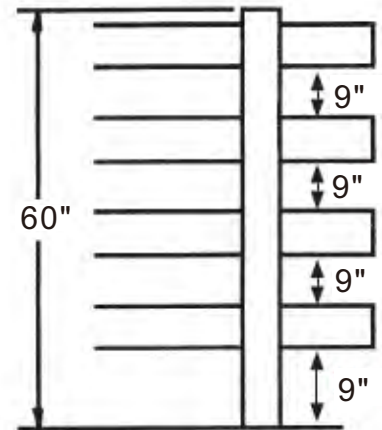

4 RAIL DIMENSIONS

## PREPARE FENCE LAYOUT

Please read this instruction sheet completely before starting work. Laying out the fence is an important first step toward a quality installation.

**NOTE:** Ranch Rail fences are designed for level terrain. For Significant slopes in the terrain you will need to modify some of the posts and rails. Filing out the routed holes in the posts will help with assembly on un-even terrain.

### STEP 1

Locate the boundary lines to your property.

### STEP 2

Drive stakes into the ground along the property line and stretch a string between each stake. We recommend that all posts be set approximately 4"-6" inside of the property line to make sure that the concrete footings do not go over your property line.

### STEP 3

Mark the location of each post hole. Ranch Rail fence hole locations should be 96" on center. A can of bright colored spray paint or colored flags work well to mark out holes.

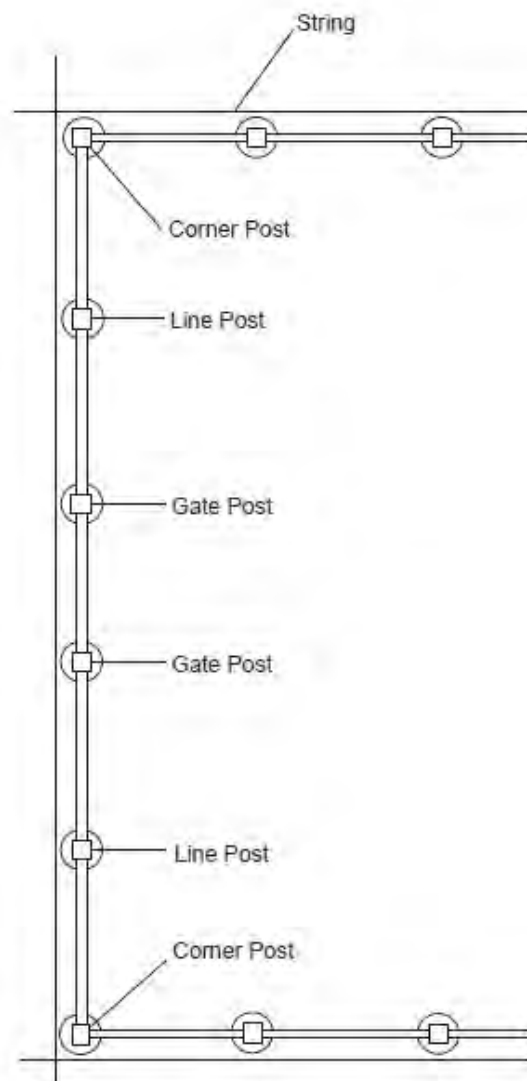

## SETTING POSTS

### STEP 1

Dig holes 8" - 10" in diameter and anywhere from 24", 30" or 36" deep depending on your local weather and soil conditions.

### STEP 2

Position the post in the hole. The post should be centered in the hole and must be square with the fence line so that when the rails are inserted into place they will parallel the string line. Check the post on two adjacent sides with a carpenter's level and adjust as necessary to make sure it is plumb. The fence height above grade is also determined at this time.

### STEP 3

Pour concrete around the posts and fill up to ground level. Wet or dry concrete works fine. If using dry concrete water down around the posts when you are ready for the concrete to start setting up. The concrete will be set up in about 24 hours. Repeat this step until all post are set and ready for rail insertion and gate install if needed.

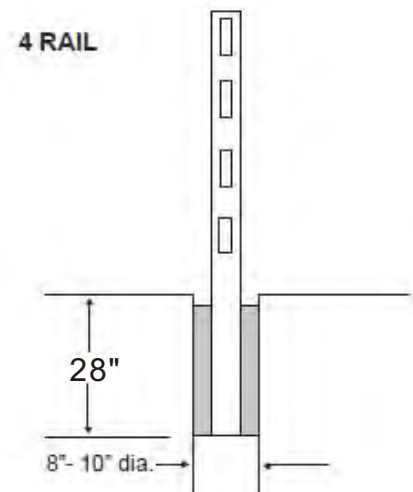
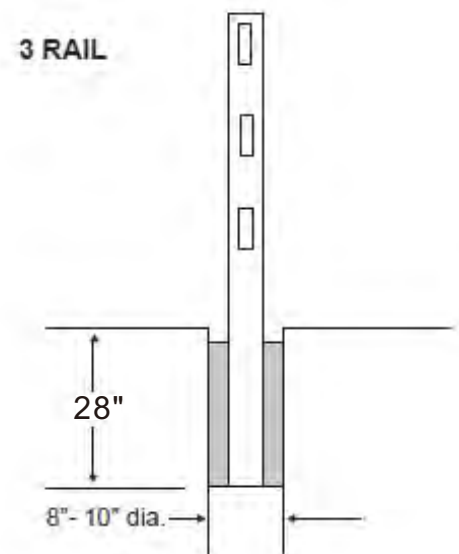
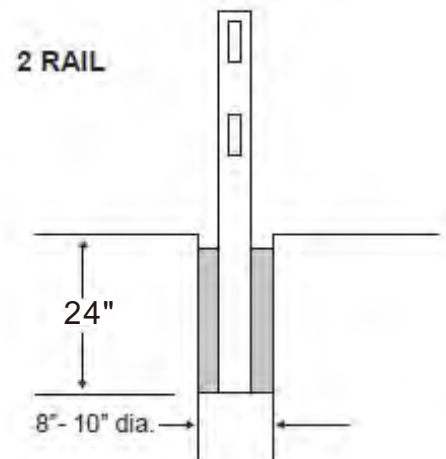

## RAIL INSTALLATION

### STEP 1

Slide bottom rails into cutouts in the post. The notches on the rails will lock the rail into the post.

### STEP 2

Slide the other side of rail into post and lock it. If post spacing is less than 8' on center, cut a piece of rail to achieve desired length. Any power saw works well to cut these rails. You can purchase a notching tool to re-notch the rail or in most cases you can put a screw into the cut rail to hold it in place.

### STEP 3

Repeat above steps to finish other rails, and the next sections...

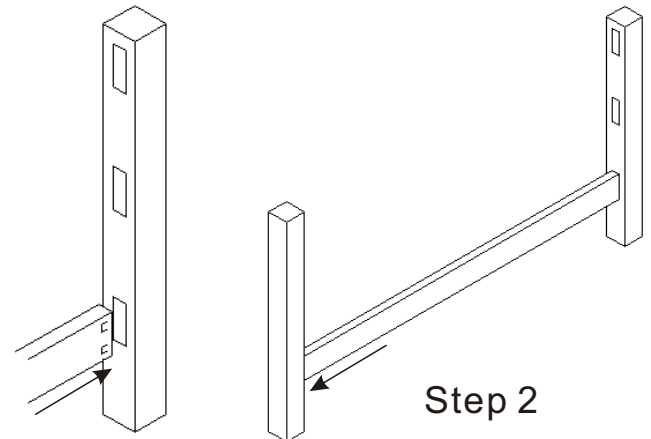

Step 1

Step 2

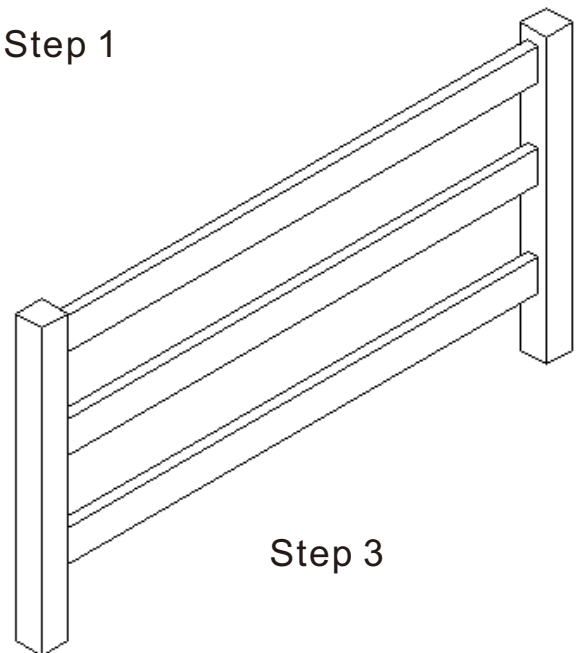

Step 3

## POST CAP

Apply pvc glue to the inside of the cap and press completely onto the top of the post. Press firmly to ensure that the cap is on as far as it will go.

